

Coupling Thermal Analyzer

- To **Fourier Transform Infrared** Spectrometers
- Concepts, Instruments and Applications



• About us

Bruker entered the field of FT-IR spectroscopy in 1974. The early instruments set new standards in research FT-IR with evacuable optics, high resolution and automatic range change. Since then, the product line has been continuously expanding with instruments suitable for both analytical and research applications with exceptional performance characteristics.

Bruker led the way establishing FT-Raman as a major new analytical technique in the late 1980s. The introduction of dedicated FT Near IR systems for QA/QC has enhanced the reputation of Bruker Optics as a leading supplier of FT-IR and FT-Raman instrumentation.

With service centers all over Europe, North and South America, Asia and Oceania an efficient global technical support is guaranteed. This includes a professional installation as well as qualified and fast after sales service and, if desired, remote diagnostics.

The NETZSCH Group is a mid-sized, family-owned German company engaging in the manufacture of machinery and instrumentation with worldwide production, sales, and service branches.

When it comes to Thermal Analysis, Calorimetry (adiabatic & reaction) and the determination of Thermophysical Properties, NETZSCH has it covered. 50 years of application experience, broad state-of-the-art product line and comprehensive service offerings ensure that NETZSCH solutions will not only meet your every requirement but also exceed your every expectation.

• Hyphenated FT-IR for Thermal Analysis

More Than Just the Sum of its Parts



Perfect Combination Bridges the Analytical Gap and Facilitates Fingerprint Analysis

Thermal Analysis provides ideal tools for the characterization of all kinds of organic and inorganic solids and liquids. Thermodynamic transitions, thermal stability, decomposition and chemical reactions can be detected and quantified with high accuracy over a broad temperature range.

In some cases, however, information about the type of gases evolved is needed in order to gain a detailed understanding of the chemistry behind the processes. The combination of thermal analysis with the powerful infrared spectroscopy for the evolved gases bridges this analytical gap. It allows for deeper insight into the material's behavior and may provide a fingerprint of the analyzed material.

The Proteus® software for thermal analysis and the OPUS software for the FT-IR measurement are integrated with one another to support the Thermal Analysis-to-FT-IR coupling. The relationship to temperature and time of all information produced by the running experiment is meticulously maintained.

Harmonized Instrument Combinations with Fully Integrated Software from the Specialists in Thermal Analysis and IR Spectroscopy

Optimized low-volume gas cells
without mirrors inside

01

Vacuum capability
for oxygen removal, elimination of carryover, and lowering of boiling points

02

03

04

Parallel operation for regular FT-IR experiments
or for hyphenated tests without modification and disassembling (by use of an external gas cell)

High resolution and high sensitivity

Great Variety of Configurations to Meet all Needs

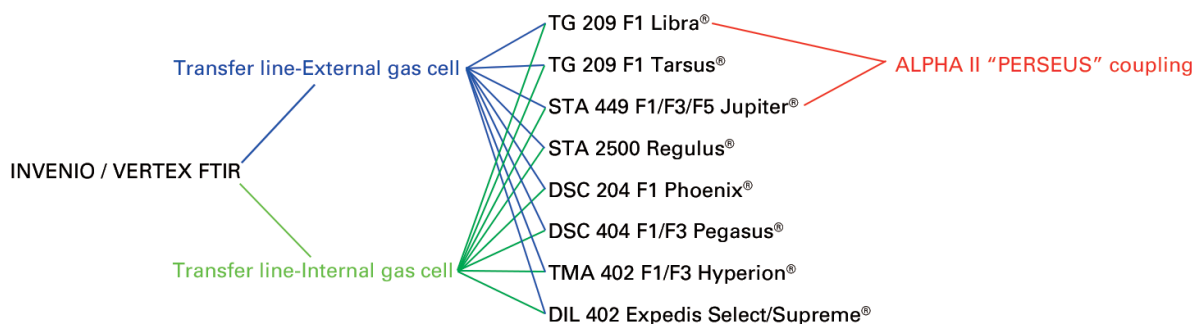

Additionally MS or GC-MS can be added to most combinations

• Sophisticated Gas Cell Design

To ensure highly sensitive detection of the gases evolved, it is necessary to have a gas cell with a long path length and low volume. The longer the path length, the more molecules are passing through at any given moment. On the other hand, the gas concentration is also influenced by the volume of the gas cell. The lower the volume, the higher the concentration of the gases evolved.

Developed in a collaboration between NETZSCH Analyzing & Testing and Bruker Optics, the beam-conforming metal gas cells with their optimized gas flows perfectly combine these requirements.

An additional advantage to this design is that the absence of an internal mirror prevents particle condensation, thus also preventing any influence to the detection sensitivity by a polluted mirror surface.

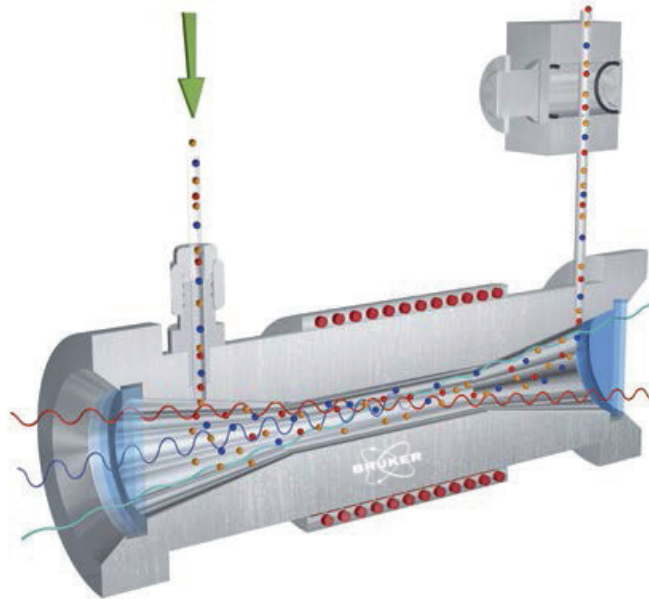

Characteristics of Available Gas Cell Types:

Type	Gas cell for INVENIO & VERTEX (internal or external)	Gas cell for PERSEUS® coupling (only internal)
length	123 mm	70 mm
volume	8.7 ml	5.8 ml
windows	dual windows technique: KBr windows (outer face) and ZnSe windows (inner face)	ZnSe windows
windows removal for cleaning purpose	✓	✓

Capabilities for Reduced Pressure

The spectrometers used for coupling typically work in the mid infrared range (MIR) and are operated under normal pressure. But for special tasks, a reduced pressure is also possible.



Windows of the external gas cell for INVENIO with screw thread; double window technique for safe cleaning and removal

• TGA/STA-FT-IR Coupling for Maximum Flexibility



All NETZSCH thermobalances (TGAs) and simultaneous thermal analyzers (STAs) are characterized by their vertical, top-loading design. This not only guarantees easy operation and sample loading, but is also in accordance with the natural gas flow path inside the furnace (warm gases have the tendency to rise) and protects the balance in an optimal way.

Because of this natural gas flow path, top-loading thermobalances are ideally suited for coupling to evolved gas analyzers such as FT-IR spectrometers, mass spectrometers and/or GC-MS systems (gas chromatograph-mass spectrometers) – and for most instruments, this can also be combined with an automatic sample changer (ASC).

Three Modes of Connecting FT-IR to a Thermal Analyzer:

- Coupling to an external gas cell via transfer line for highest FT-IR system flexibility (e.g. INVENIO)
- Coupling to an internal gas cell via transfer line using the FT-IR sample chamber (e.g. INVENIO)
- Direct PERSEUS® coupling without transfer line

Defined Gas Atmosphere

Fourier Transform Infrared Spectroscopy is extremely sensitive to water and carbon dioxide. It is therefore important to establish a pure inert gas atmosphere at the sample and to minimize the H₂O and CO₂ background in the FT-IR spectra.

In order to achieve this requirement, all TGA/DSC/STA-FT-IR systems are vacuum-tight or gas-tight.



STA 2500 *Regulus*
with transfer line for
STA-FT-IR coupling.

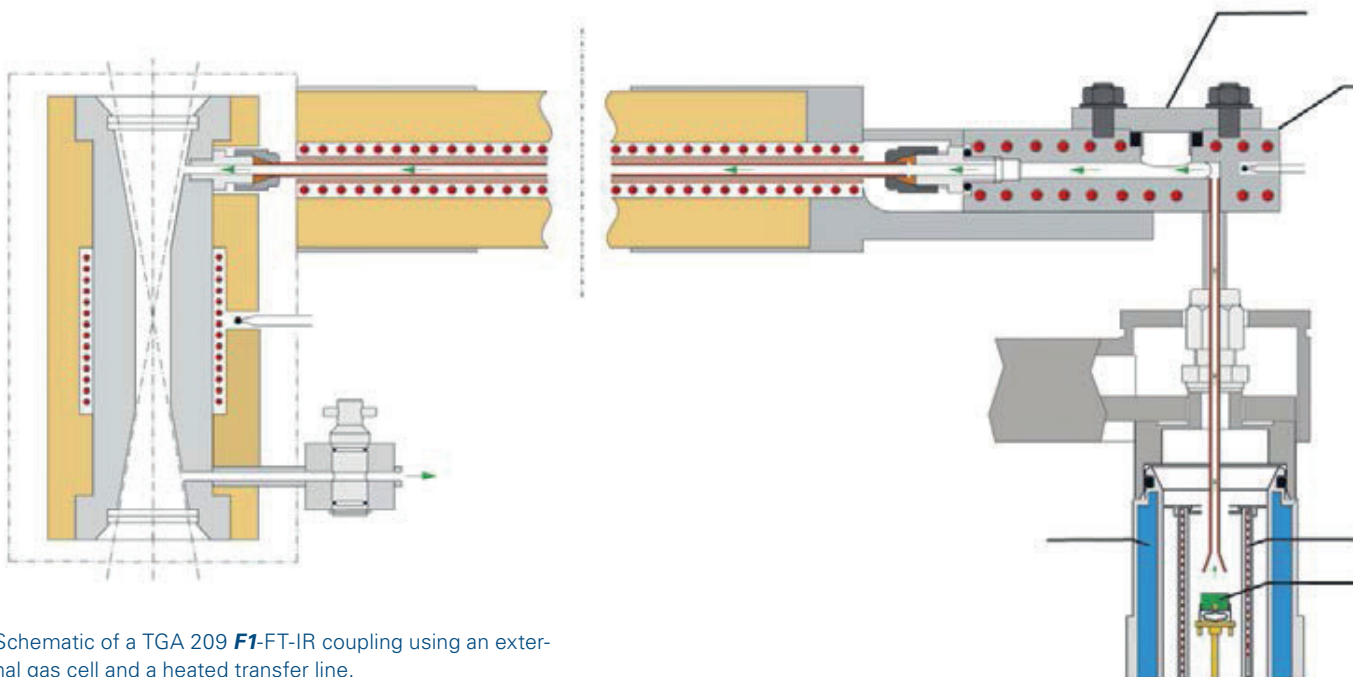

Schematic of a TGA 209 **F1**-FT-IR coupling using an external gas cell and a heated transfer line.

Prerequisite for Effective Coupling

An adapter together with a short transfer line should connect the gas outlet of the TGA, DSC or STA furnace to the gas cell of the FT-IR spectrometer. The evolved gases are transferred using a carrier gas (usually nitrogen).

To prevent cold spots and thus condensation of the gases evolved, the entire gas path should be heated. The temperatures are up to 300°C for the adapter and max. 230°C for transfer line.

The Right Detector for any Application

Built-in DLaTGS (deuterated triglycine sulfate), detectors are standard for Bruker INVENIO and ALPHA II systems. They do not require any additional cooling and are therefore particularly well-suited for TGA/DSC/STA test runs with an automatic sample changer (ASC) or for measurements of longer duration.

The external gas cells are equipped with MCT detector (Mercury-Cadmium-Telluride) by default. They provide a significantly higher signal-to-noise ratio (compared to DLaTGS) and require liquid nitrogen cooling.

Advantages of the NETZSCH-BRUKER TG-IR

- Short transfer path
- Continuously heated interface and gas cell
- Minimized risk of condensation
- Mirror-free gas cell
- Tests with automatic sample changer for high sample throughput and great variability of measurement parameters

● PERSEUS®

A New Way of Coupling Thermal Analysis and FT-IR



PERSEUS® TG 209 **F1**

PERSEUS® TG 209 **F1** - Get Rid of Transfer Line

PERSEUS® is the unique combination between a NETZSCH thermobalance (or STA system) and the tiny Bruker Optics ALPHA II FT-IR spectrometer. Its revolutionary layout sets a benchmark for state-of-the-art hyphenation.

The PERSEUS® coupling interface excels in both design and ease of handling. The built-in heated gas cell is directly connected to the gas outlet of the furnace via a heated tube. The gas cell temperature is regulated and controlled directly by OPUS software. Additionally, the PERSEUS® features an extremely small footprint.

INVENIO FT-IR spectrometer connected with STA 449/F1 Jupiter® system. The combination for the experts laboratory with highest optical throughput and sensitivity. Nearby unlimited possibilities offered by simple mouseclick. The INVENIO's large sample compartment may hold accessories out of the full FTIR portfolio; additionally the small "Transit" sample chamber is still open; all beside the installed TG-FT-IR equipment.



Bruker INVENIO with external gas cell

STA 449 **F1** Jupiter®

Space-Saving PERSEUS® STA 449

PERSEUS® STA 449, the powerful, cost effective TG-FT-IR features a compact 2-in-1 design which saves over 50% of the bench top space two separate systems use. The short gas path with low volume provides an excellent correlation between mass losses and the gases detected.

In order to minimize the risk of condensation, the PERSEUS® coupling interface is heated using a constant voltage. Optionally, a temperature control system is available (recommended for condensable gases). The maximum temperature of the entire gas path is set to 200°C. Existing STA 449 system can be upgraded to the PERSEUS® configuration. Various furnaces for the temperature range from RT to 2000°C are available for this kind of coupling.

A GC-MS system for gaining additional information may be optionally added.

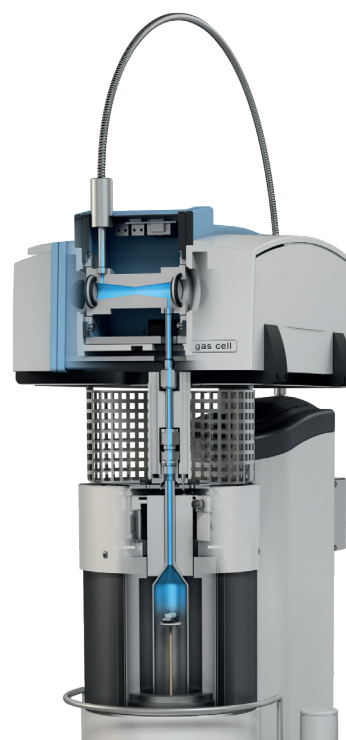

Schematic of the gas path of a PERSEUS® STA system

PERSEUS® Coupling

PERSEUS® STA 449 **F1** Jupiter®



Room Temperature Detector instead of Liquid Nitrogen Cooled One

The DLaTGS detector (DLaTGS = L-alanine doped deuterated triglycine sulfate) employed in the spectrometer works at room temperature and requires no liquid nitrogen for cooling. The PERSEUS® system is thus perfectly suited for tests with an automatic sample changer (for up to 204 samples in the TG 209 **F1** or 20 in the STA 449).

The use of DLaTGS instead of MCT offers somewhat lower sensitivity but adds comfort. In combination with ALPHA II's high sensitivity and the lower cell volume the combination offers ideal conditions for routine applications.

Side-Step

• Why Combine DSC with EGA-FT-IR (DSC Dynamic Scanning Calorimetry) (Evolved Gas Analytics)

Usually, TGA-FT-IR experiments study decomposition processes. In contrast, the temperature profiles of DSC-FT-IR measurements are designed to avoid thermal degradation of the sample or to stay maximally at processing temperature of, e.g., polymers.

The main focus of DSC investigations is to analyze phase transitions such as melting and crystallization or structural changes. However, gaseous substances such as moisture or adsorbed solvents sometimes evolve. These can then be characterized using FT-IR, MS or GC-MS.

The plot shows a DSC-FT-IR measurement on citric acid monohydrate ($C_6H_8O_7 \times H_2O$). Between 30°C and 100°C, two superimposed DSC effects are visible (red curve). According to literature, the melting of citric acid monohydrate is accompanied by dehydration.

In the temperature range from 130°C to 250°C, two additional superimposed effects occur. The peak at 156 °C is associated to melting of citric acid and directly followed by its decomposition. This is reflected by a sharp increase in the intensity of the IR absorbance bands detected.

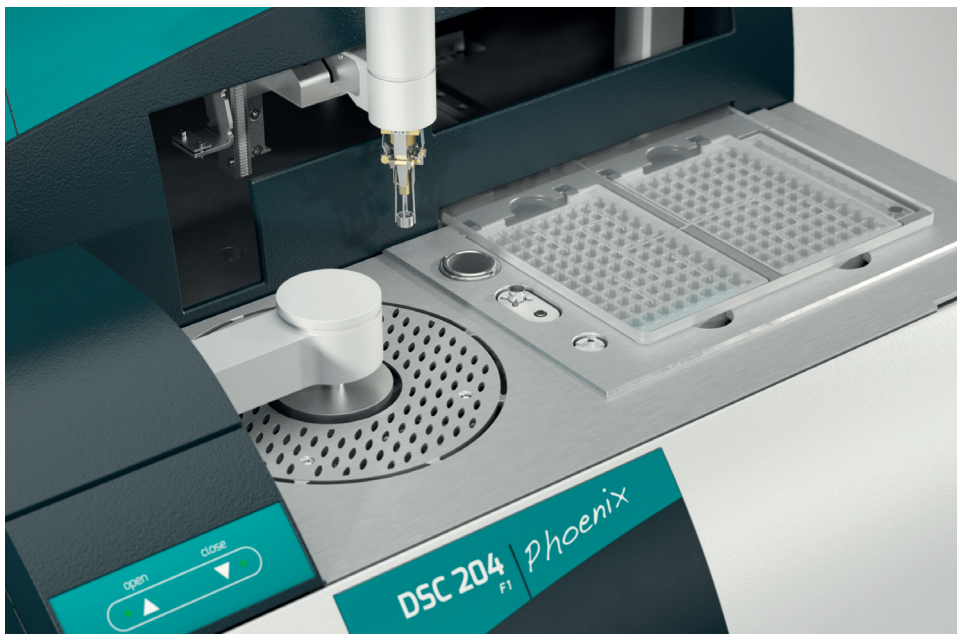

DSC 204 **F1** Phoenix® with automatic sample changer (ASC)

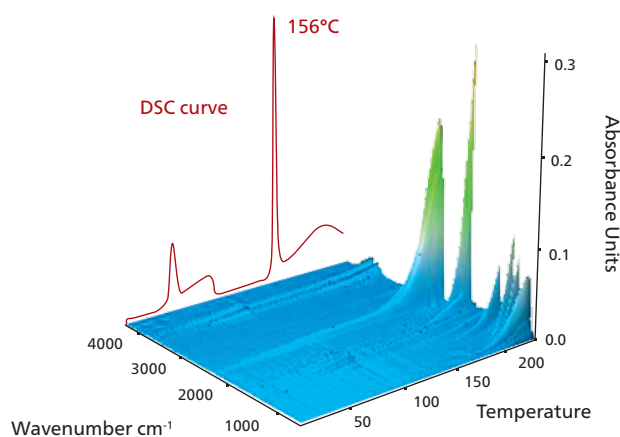

Measurement of 7.7 mg of citric acid monohydrate at a heating rate of 5 K/min in a nitrogen atmosphere; 3-D presentation of the measured FT-IR spectra including the corresponding DSC curve in red.

• PulseTA®

A Clever Tool for Calibration, Quantification and Catalysis Studies

PulseTA® technique is used to inject a defined amount of gas into the purge gas flow of a thermobalance (TGA) or simultaneous thermal analyzer (STA) and then monitor the corresponding changes in the sample mass, enthalpy or evolved gases.

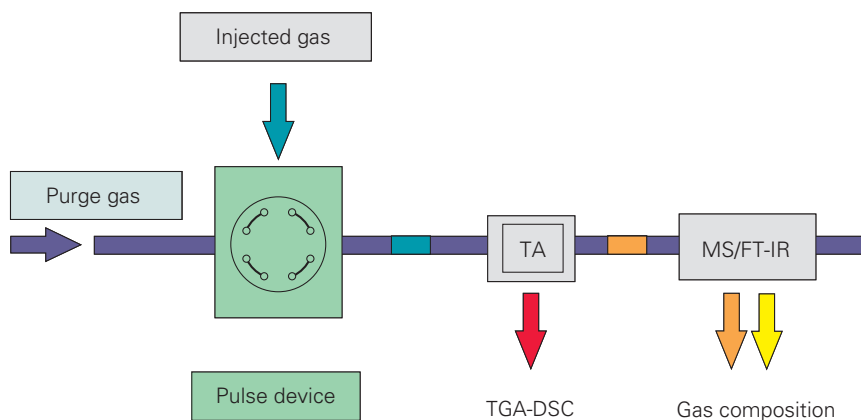

PulseTA® allows for three types of thermoanalytical experiments:

1 Injection of a gas which adsorbs at the sample surface

This mode offers the means to study adsorption/desorption phenomena at atmospheric pressure and at a specific temperature.

2 Injection of a gas which chemically reacts with the sample

This mode provides the opportunity to investigate all types of solid-gas reactions at incremental reaction extents (e.g., stepwise control of catalytic processes by pulsed supply of the reactive gas).

3 Injection of an inert gas

As the amount of the injected gas is known, this mode can be used for calibration of the coupled TGA/DSC/STA-FT-IR instruments for quantification purposes.

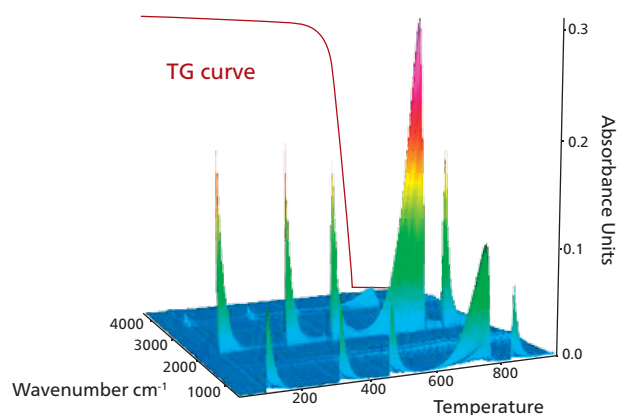

3-D plot for CO₂ calibration pulses and CaCO₃ decomposition; pulses for quantification need to be repeatable and temperature-independent (a linear relationship to the injected gas concentration)

• Comprehensive Software

Bruker OPUS and NETZSCH Proteus® - Unrivaled Combination

The alliance between the NETZSCH Proteus® software and the OPUS FT-IR software is based on effective data exchange and serves to unify the coupled system functionally.

Measurements are controlled via the NETZSCH Proteus® software. The user only needs to input the command for data acquisition and for the start of measurement once, and both the OPUS and Proteus® software will be readied with parameter inputs. Online data collection is simultaneous and synchronized to guarantee precise time and temperature correlation between all signals from the two coupled instruments during evaluation.

The user operates the two software packages from a single computer and has access to the full range of possibilities for data evaluation and results display in either package at any time.

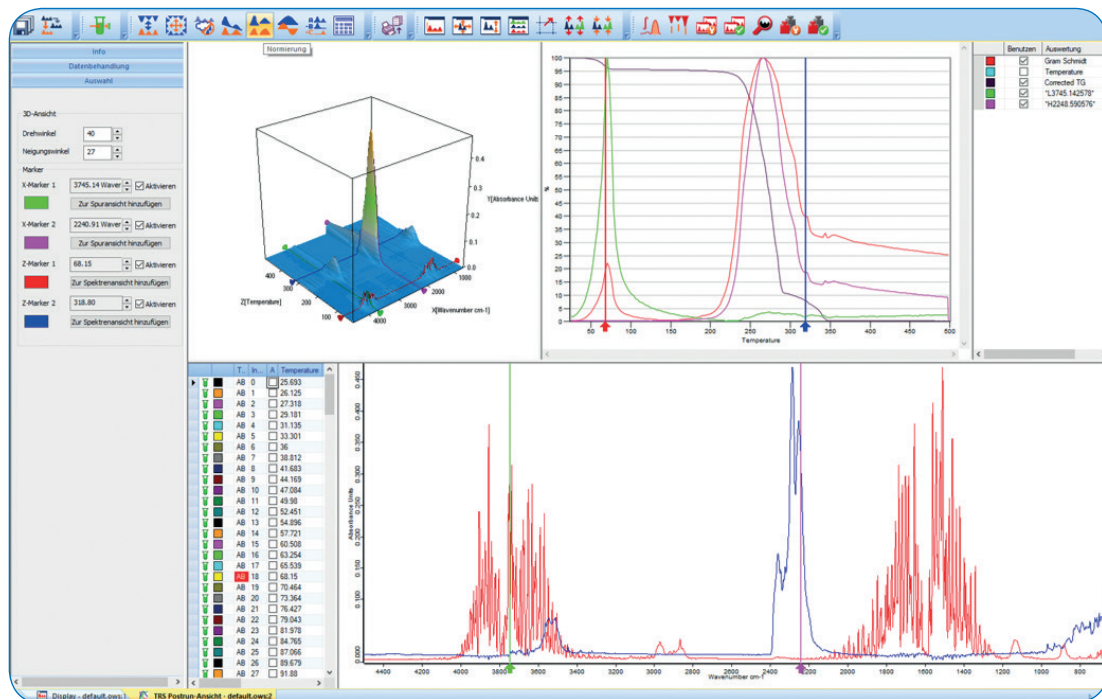

Screenshot of the OPUS software during the evaluation of a drug sample:

Multi –window presentation containing a 3-D diagram (x-y-z view, with temperature information from the thermal analysis system), a trace window representing the total IR chromatogram (GS-trace), TGA-curve and interactively selectable intensity traces and the spectrum window representing the spectra at the position of the colored lines in the 3-D diagram

• Convenient Software Setup for Maximum Ease of Use

- Full software integration – online data exchange between the two instrument software packages during the running experiment
- Simultaneous instrument control and start-stop function
- Segmental activation or deactivation of the FT-IR coupling with one mouse click
- Automatic saving of data sets for both measurements (TGA and FT-IR) with identical file names (but different extensions) in the same directories
- Measurements with automatic sample changer allow for individual FT-IR measurement parameter for each position
- Conjoint presentation of the Gram-Schmidt plot plus up to four pre-selected traces together with thermal analysis curves in Proteus® software during the experiment
- Online evaluation (SNAP SHOT) of TGA/STA/DSC measurements already including FT-IR data during the measurement
- Trace calculations with evaluation of characteristic temperatures and peak areas together with TGA and DSC curves
- Combined analysis graphics of thermal analysis and FT-IR signals
- Multi-component search in OPUS
- Identification by various gas phase libraries, e.g., TGA-FT-IR library of polymers by NETZSCH

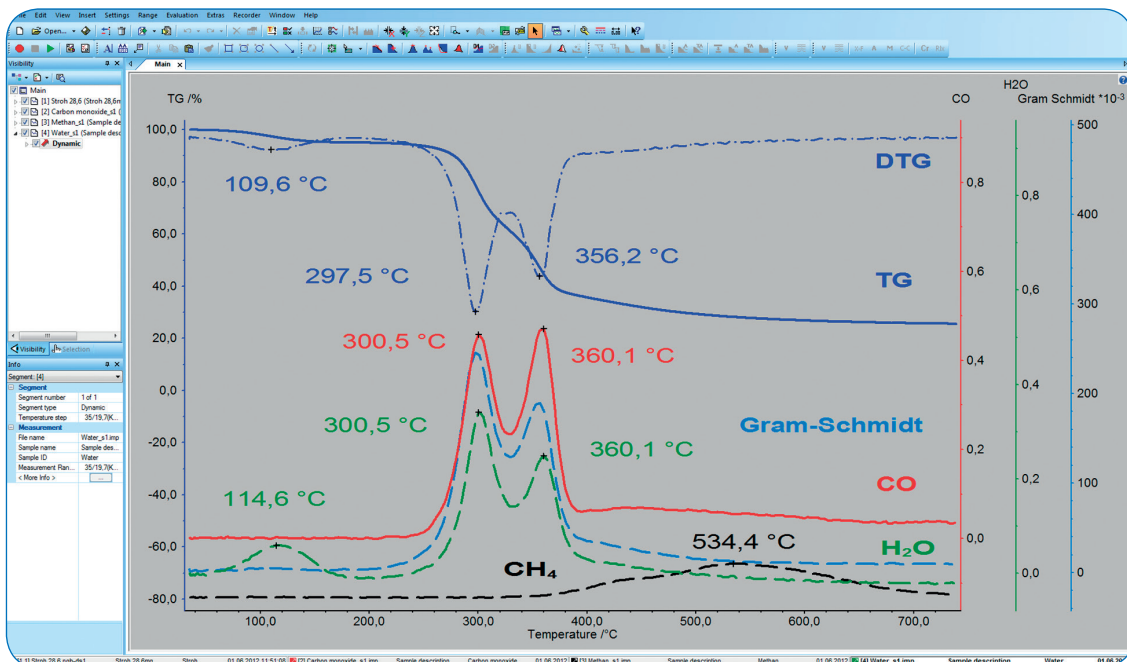

Screenshot of the Proteus® software during evaluation of a straw pyrolysis experiment: Temperature-scaled plot of the TGA and DTG curves together with the Gram-Schmidt plot and the calculated traces of methane, water and carbon monoxide (course of the absorption intensity of a specific band)



Advanced Materials Characterization

Fourier Transform Infrared Spectroscopy is a well-known technique in analytics. Since FT-IR spectrometers can be found in so many laboratories, it is often both convenient and logical to couple these to thermal analysis systems in order to gain a deeper understanding of the decomposition or evaporation processes under investigation. Tailored libraries support evaluation and offer quick and easy spectrum interpretation.

TGA/STA-FT-IR coupling is best suited for detecting permanent inorganic gases such as HF, CO₂ or H₂O at reasonable concentrations as well as organic molecules released from polymers, pharmaceuticals, etc.

Areas of Application

- Decomposition
- Dehydration
- Residual solvent content
- Pyrolysis

Solid-gas reactions

- Combustion
- Oxidation
- Corrosion
- Catalysis

Compositional analysis

- Binder burn-out
- Coal analysis
- Polymer content
- Ash content

Evaporation, outgassing

• Decomposition Behavior of Ethylene Vinyl Acetate (EVA)

EVA is a semi-crystalline thermoplastic which is often used in the production of sport-shoe soles but is also applied in the textile industry, in agriculture and horticulture, and as a hot melt adhesive.

When heated in a nitrogen atmosphere at 10 K/min, EVA is stable up to approx. 300° C and decomposes afterwards in two steps.

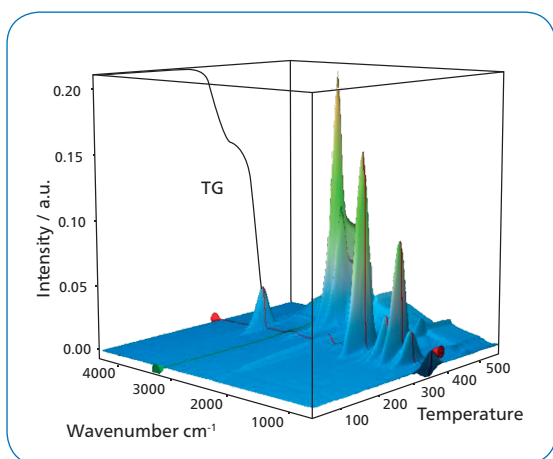

TGA curve

To identify the decomposition products, 2-D spectra can be extracted from the 3-D cube shown above and subjected to a library search. In the present case, analysis of the FT-IR absorption intensities shows the release of acetic acid and various hydrocarbons.

Correlation with the corresponding TGA curves (lower plot) reveals that acetic acid evolves solely in the 1st mass-loss step (at approx. 350°C), whereas the polymer backbone – illustrated by C-H vibrations – collapses within the 2nd mass-loss step (DTG peak at 468°C) after the acetic acid has all been fully released.

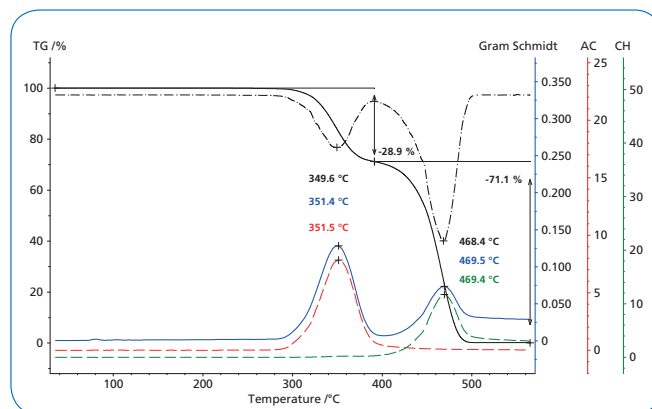

PERSEUS® TGA: Combined presentation in the Proteus® software of TGA (black solid) and DTG (black dashed) curves in correlation with the Gram-Schmidt curve (blue) as well as with the individual absorption intensities of acetic acid (red) and CH (green), respectively.

● Decomposition Behavior

... of a Medical Drug

● Aspirin®

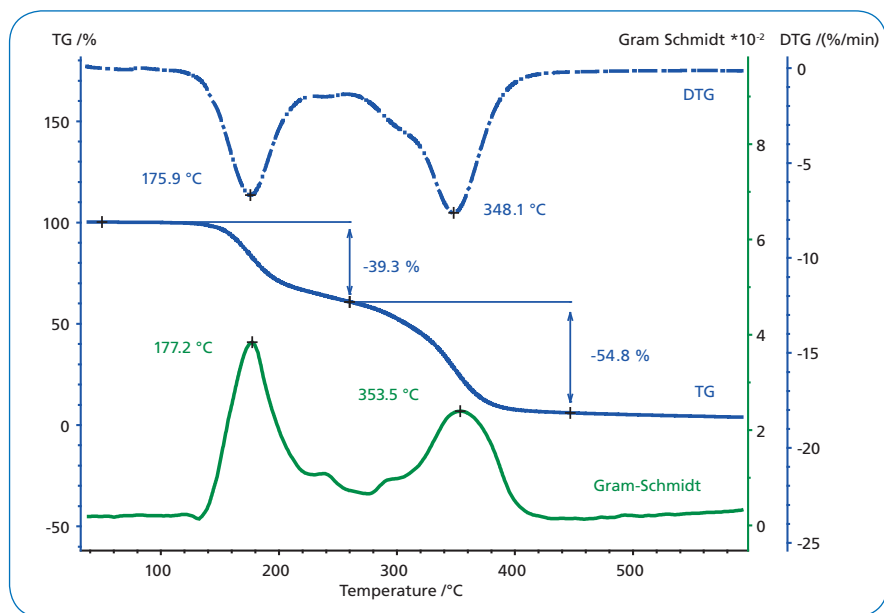

TGA-FT-IR experiment on Aspirin®; sample mass: 9.14 mg, Al₂O₃ crucible, heating rate: 10 K/min, N₂ atmosphere; combined presentation of TG curve (blue solid), DTG curve (blue dashed) and Gram-Schmidt plot (green)

Acetylsalicylic acid is the active ingredient in Aspirin®. In a humid environment, the acetyl group of this compound is very sensitive to hydrolysis. Adding excipients and coating the tablets with paraffin possibly suppress this reaction.

Aspirin® was heated up to complete decomposition, leading to two main mass-loss steps (according to the TGA and DTG profiles). The FT-IR analysis of the gas phase above the sample yields acetic acid, salicylic acid, phenol and carbon dioxide as key components. This result corresponds well with the reaction and decomposition scheme of acetylsalicylic acid which can be found in literature. The high boiling components are efficiently transferred through the heated transfer line to the gas cell and clearly detected by FT-IR.

The boiling point of salicylic acid is specified as 211°C and that of phenol as 181°C, both at a surrounding pressure of 1013 mbar.

Stability, shelf life and residual solvents are essential in drugs and excipients

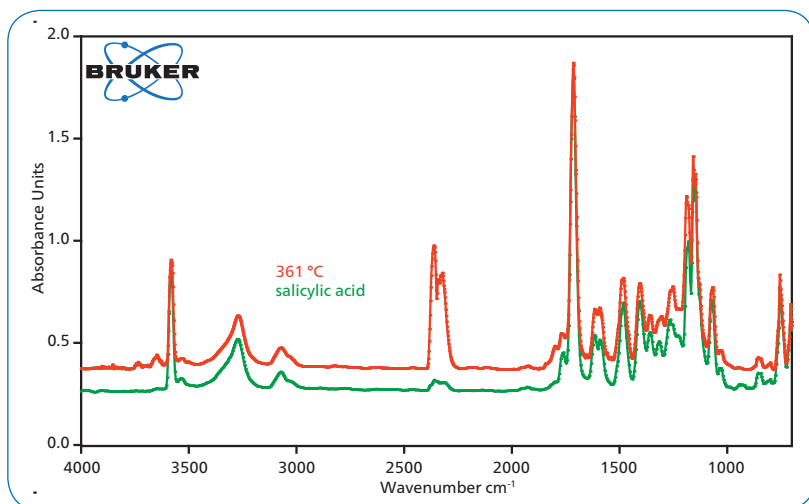
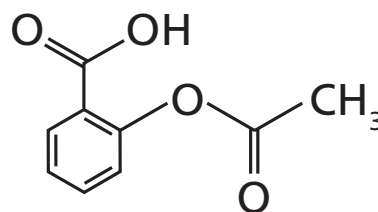

Measured FT-IR spectrum at 361 °C (red) compared to the database spectrum of salicylic acid (green).

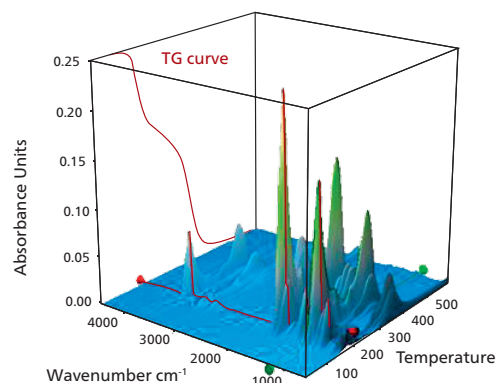

TGA-FT-IR experiment, 3-D presentation of the measured FT-IR spectra and TGA curve (red)

... of Metabolic Waste

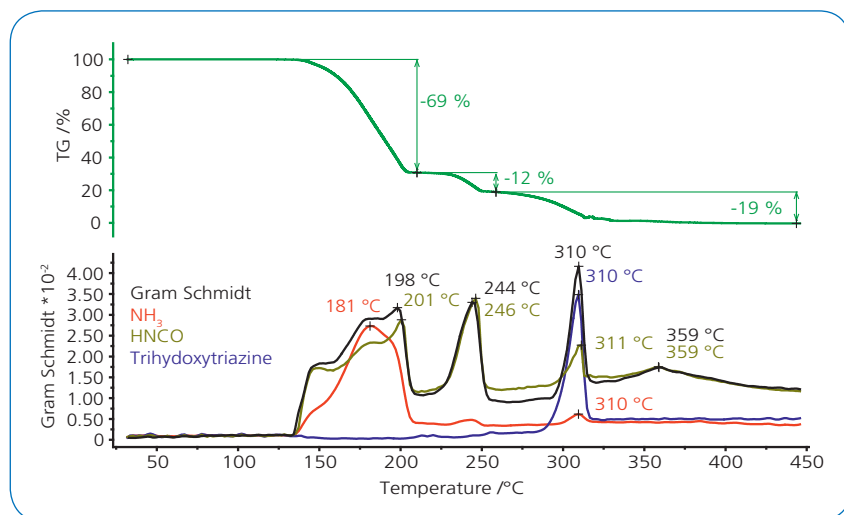

Measurement parameter: PERSEUS® TG 209 **F1**, RT – 450°C, nitrogen atmosphere, heating rate 5 K/min, gas flow 40 ml/min

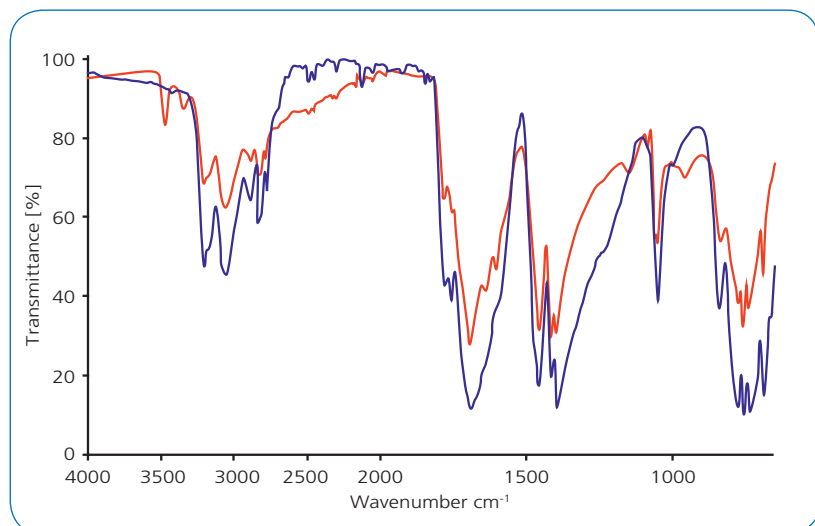
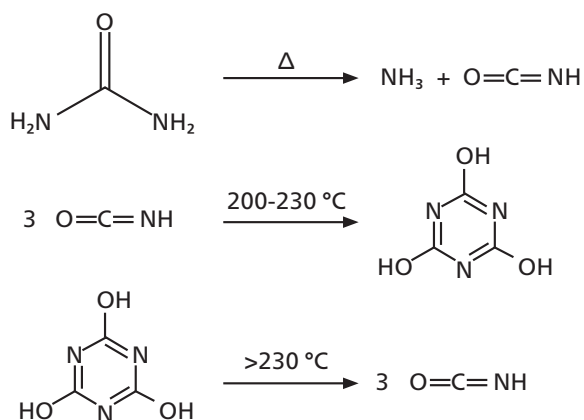

ATR spectrum of crucible residue at 200°C (red) compared to the database spectrum of Trihydroxytriazine (blue)

The use of urea can be diverse. It ranges from the production of melamine, to the use in fertilizers, to cosmetic and pharmaceutical applications. The information about thermal stability therefore plays an important role.

Investigations by TGA-FT-IR showed a three-step thermal decomposition. During the first mass-loss step ammonia and fulmic acid (HCNO) are formed, which could be detected by FT-IR. Above 200°C, fulmic acid reacts to cyanuric acid (trihydroxytriazine). Cyanuric acid decomposes also to fulmic acid above 230°C. During the third mass-loss step, the complete cyanuric acid was detected in the gas phase. This is in good agreement with literature data.

Cyanuric acid can also be detected by ATR-FT-IR in the crucible if the reaction is stopped at 200°C.

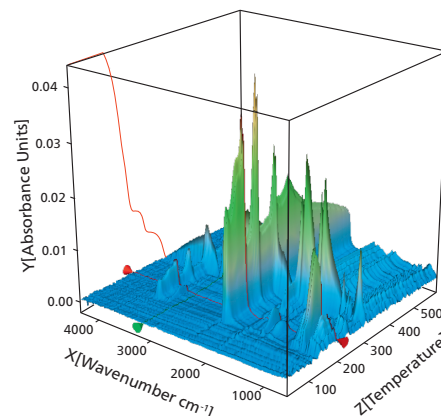

• Firing of Clay

To save energy in buildings, wall constructions should have low thermal conductivity. One way to achieve this is to use highly porous building bricks. Various organic products, capable of generating a high volume of voids, are mixed into the clay to form cavities during firing.

In this example, 107.6 mg of a clay green body was heated at a rate of 10 K/min in Pt/Rh crucibles in flowing air (50 ml/min). The predominant effect during heating is the burnout of the organics between 200°C and 550°C, which is accompanied by a high energy release (775 J/g).

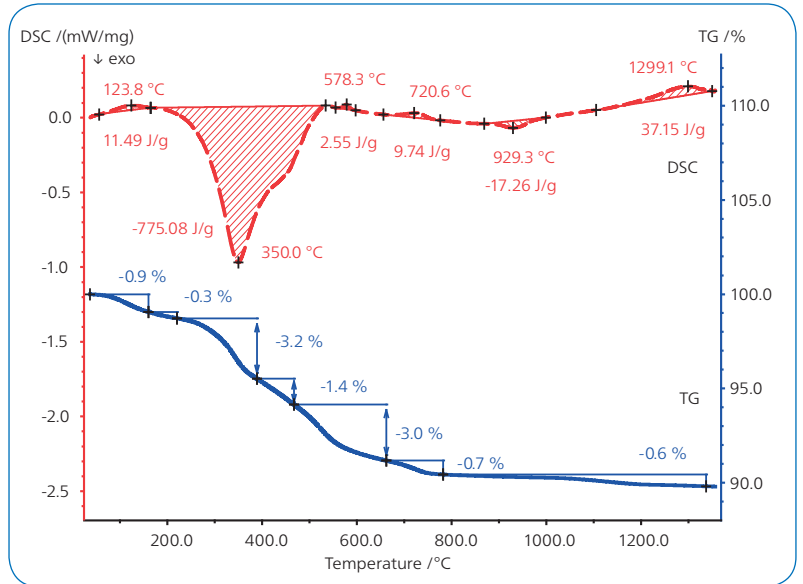

Mass changes and energetic changes of a clay for porous bricks; presentation of the TGAS curve (blue) and the corresponding DSC curve (red)

The main volatiles emerging during this process are water and carbon dioxide, but the FT-IR also clearly detects the evolution of HF (around 4000 cm⁻¹) and SO₂ (around 1300 to 1400 cm⁻¹) from the clay (red circles).

Identification of such emissions allows for optimization of the firing process from both economical and ecological standpoints.

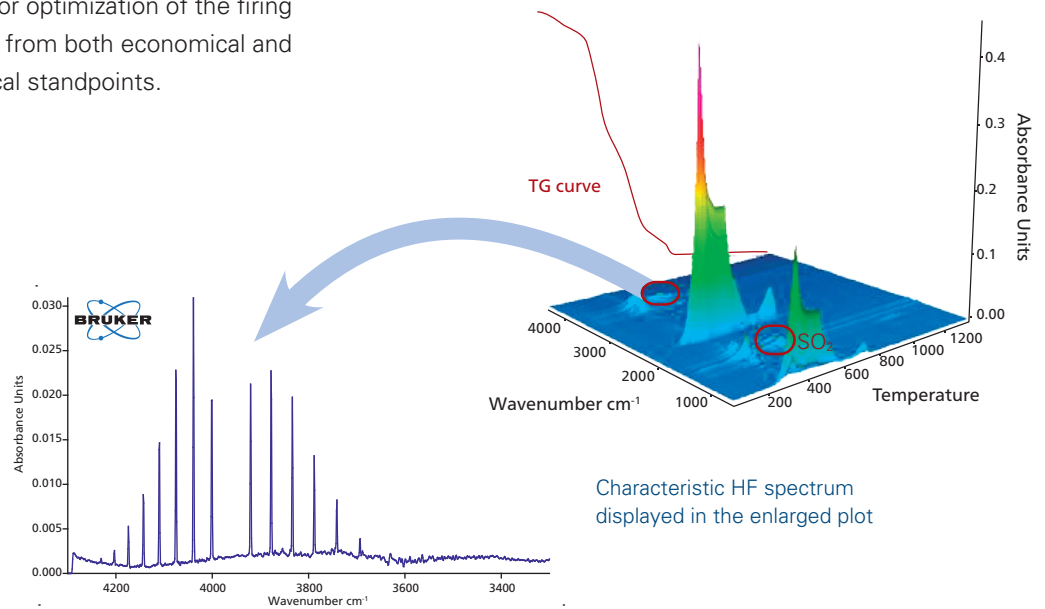

• Process Optimization

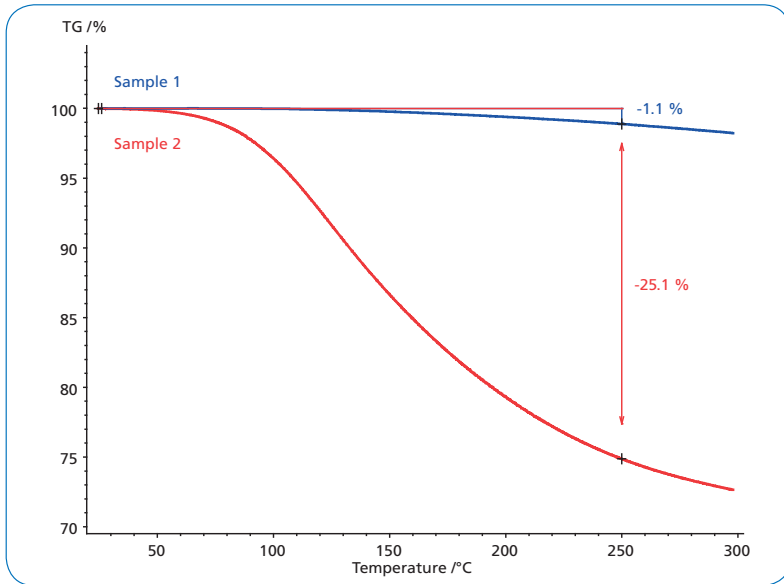

Comparison of the TGA results of two TGA-FT-IR experiments; sample masses: 24.5 mg and 26.3 mg, Al₂O₃ crucibles, heating rate: 10 K/min, N₂ atmosphere

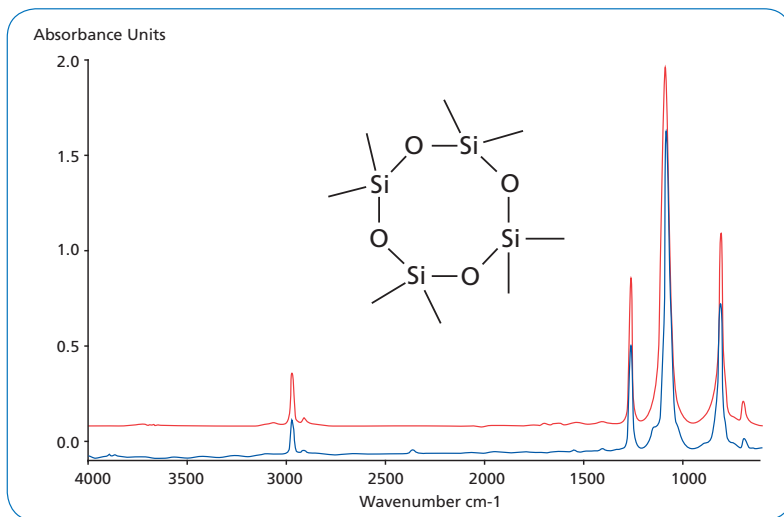

Comparison of the measured spectrum extracted at 126°C and the results of the library search (cyclooctamethyltetrasiloxane)

Manufacturing of Silicones

Here, two control samples of silicones were tested – one of them (sample 2) revealed manufacturing problems. The TGA curves exhibit significantly different thermal behavior. Sample 2 loses approx. 25% of its weight whereas the mass loss for sample 1 is only about 1% up to 250°C.

To identify the gases evolved, a single spectrum was extracted at the point of maximum IR intensity and mass-loss rate (about 126°C; DTG curve not demonstrated here). Library comparison suggests cyclo-octamethyltetrasiloxane with a perfect agreement in band pattern with the experimental spectrum.

The polymerization mechanism for the generation of silicones often proceeds via cyclosiloxanes as intermediate products. Organochlorosilanes such as dimethylchlorosilane (CH₃)₂SiCl₂ are hydrolyzed and form silanoles which react at higher temperatures and in the presence of catalysts to become the desired product. In the present case, neither water nor the educt dimethylchlorosilane contributes to the observed mass loss. This leads to the conclusion that in the case of sample 2, the reaction was partially halted at the intermediate product.

TGA-FT-IR coupling ist most of great help in detecting causes of failure during polymer processing.

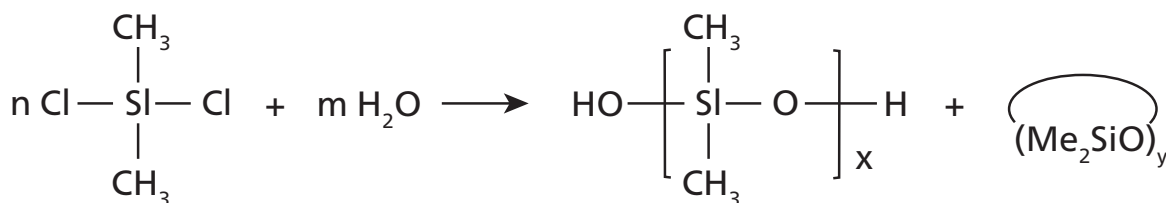

Polymerisation mechanism of silicones

● Technical Specifications

Characteristic Data for Available TGA-FT-IR Coupling Systems

Bruker FT-IR spectrometer types	INVENIO/VERTEX	INVENIO/VERTEX	ALPHA II	INVENIO/VERTEX	INVENIO/VERTEX
Netzsch TG system	TG 209 F1 Libra®; TG 209 F3 Tarsus®	DSC 404 F1/F3; STA 2500 Regulus; STA 449 F1/F3/F5	PERSEUS® STA 449; PERSEUS® TG 209 F1	TMA 402 F1/F3; DIL 402 Expedis Select/Supreme	DSC 204 F1 Phoenix®
Temperature range ⁴	RT-1000°C (F3) 10°C(RT)-1100°C (F1)	RT-1600°C (Regulus, F5) -150°C-2000°C (F1/F3)	RT-2000°C (STA) RT-1100°C (TGA)	RT-1550°C (TMA) RT-2000°C (DIL)	RT-700°C
Measurements under reduced pressure (for solvent separation)	Yes (F1)	Yes	Yes	Yes	No, atmospheric pressure only
Vacuum-tightness of the complete system	Yes (F1)	Yes	Yes	Yes	No
Additional automatic sample changer operation ¹	Yes (F1)	Yes (DSC 404, STA 449) No (Regulus)	Yes	No	Yes
Stand-alone operation of the FT-IR and/or TG	Yes	Yes	Yes	Yes	Yes
Additional analytical instruments to be coupled	MS or GC-MS (F1)	MS or GC-MS	MS or GC-MS	MS or GC-MS	MS or GC-MS
T _{max} transfer line, transfer tube/adaptor head	230°C/300°C	230°C/300°C	adaptor head 250°C	230°C/300°C	230°C/300°C
Set-up gas cell	Internal or external	Internal or external	Internal	Internal or external	Internal or external
Material gas cell	Stainless steel	Stainless steel	Nickel-coated aluminum	Stainless steel	Stainless steel
Gas cell – path length	123 mm	123 mm	70 mm	123 mm	123 mm
Gas cell – volume	8.7 ml	8.7 ml	5.8 ml	8.7 ml	8.7 ml
Detector ³	DLaTGS or MCT	DLaTGS or MCT	DLaTGS	DLaTGS or MCT	DLaTGS or MCT

- 1 MCT with longer operation time recommended
- 2 For coupling with thermal analyzer from other suppliers than Netzsch please contact Bruker
- 3 MCT detector requires LN₂ cooling
- 4 For most TG-instruments variable furnaces are required to cover the stated temperature range

Bruker Optics is ISO 9001 and ISO 13485 certified.

Laser class 1 product.

www.bruker.com/optics

● **Bruker Optics Inc.**

Billerica, MA · USA
Phone +1 (978) 439-9899
Fax +1 (978) 663-9177
info.bopt.us@bruker.com

● **Bruker Optik GmbH**

Ettlingen · Germany
Phone +49 (7243) 504-2000
Fax +49 (7243) 504-2050
info.bopt.de@bruker.com

● **Bruker Shanghai Ltd.**

Shanghai · China
Phone +86 21 51720-890
Fax +86 21 51720-899
info.bopt.cn@bruker.com